



MFPA Leipzig GmbH

Testing, Inspection and Certification Authority for
Construction Products and Construction Types

Center for Innovation and Calculation

Dr.-Ing. Susanne Reichel

Work Group - FEM

Dr.-Ing. Susanne Reichel

Telefon +49 (0) 341-6582-106

s.reichel@mfpa-leipzig.de

Advisory Opinion No. GS 6.1/20-016-1

31.03.2020

Translation of the original German document GS 6.1/20-016-1

Object:

Assessment of the load bearing behaviour of bonded anchors VMZ-A and VMZ-IG with injection system VMZ under tensile loading and one-sided fire loading according to the standard-time-temperature-curve - abbreviated version

Client:

Sikla Holding GmbH

Kornstraße 4

4614 Marchtrenk

Österreich

Prepared by:

Dr.-Ing. Susanne Reichel

This document covers 24 pages, including 0 appendices.

This document may only be reproduced in its unabbreviated form. All publication, even in excerpts, requires the prior written permission of MFPA Leipzig GmbH. The legal binding form is the written German form with the original signatures and original stamp of the authorized signatory / signatories. General terms and conditions of MFPA Leipzig GmbH are valid.

Gesellschaft für Materialforschung und Prüfungsanstalt für das Bauwesen Leipzig mbH (MFPA Leipzig GmbH)

Head Office:	Hans-Weigel-Str. 2b – 04319 Leipzig/Germany
Managing Director:	Dr.-Ing. habil. Jörg Schmidt
Comm. Register:	Local Court Leipzig HRB 17719
VAT-ID:	DE 813200649
Tel.:	+49 (0) 341-6582-0
Fax:	+49 (0) 341-6582-135



Contents

I	Objective and request	3
II	Description of the construction	4
III	References	6
1	Utilized guidelines, rules and standards	6
2	Reference documents	6
2.1	Verifications of applicability	6
2.2	Assessment and test reports	7
2.3	Miscellaneous	7
IV	Assessment of the performance	8
1	Design concept	8
2	Pull-out failure	9
3	Steel failure	15
4	Concrete cone failure	21
V	Special notes	23

I Objective and request

MFPA Leipzig GmbH was ordered by Sikla Holding GmbH to assess the load bearing behaviour of bonded anchors VMZ-A and VMZ-IG with Sikla injection system VMZ (mortar cartridge VMZ or VMZ express) under tensile loading and one-sided fire loading according to the standard-time-temperature-curve (STTC) according to [N1]. The assessment bases on results of fire tests and numerical simulations and includes the failure modes "steel failure", "pull-out failure" and "concrete cone failure".

The document at hand summarizes the design concept in case of fire and the corresponding characteristic tensile load bearing capacities. For the detailed derivation of the values, please see [G1] in conjunction with [S1].

II Description of the construction

The Sikla injection system VMZ is a bonded anchor for use in concrete constructions, consisting of a mortar cartridge VMZ or VMZ express, an anchor rod with cones as well as a hexagon nut and a washer. Concerning the anchor rod, the variants "anchor rod" VMZ-A and "internal threaded rod" VMZ-IG may be distinguished according to [P1].

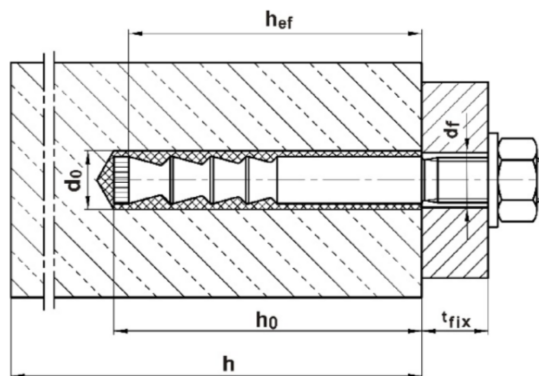

Figure 1: Sikla injection system VMZ with anchor rod VMZ-A: On-site geometry, from [P1]

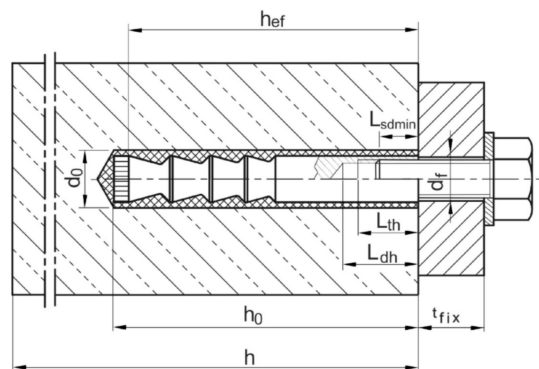

Figure 2: Sikla injection system VMZ with anchor rod VMZ-IG: On-site geometry, from [P1]

Load transmission mainly occurs due to the mechanical tothing of the cones within the injection mortar as well as, in addition, a combination of cohesion and friction forces in the anchorage. The bonded anchors are approved for the use under static and quasi-static loading in reinforced and unreinforced normal concrete of the strength class of at least C20/25 and at most C50/60 according to [N2]. The required diameter and depth of the drill hole as well as the minimum component thickness are specified for



each anchor in [P1]. In the course of installation of the bonded anchors, the manufacturers' instructions have to be obeyed (see [P1]). According to [P1], the anchor rods of the Sikla injection system VMZ are available in three different materials:

- galvanized steel according to [N3],
- stainless steel A4 according to [N4],
- high corrosion resistant steel according to [N4].

For a detailed product description and further information with respect to the scope of application, please see [P1].

III References

1 Utilized guidelines, rules and standards

The analyses are based on the following guidelines, rules and standards:

- [N1] DIN EN 1363-1:2012-10: Fire resistance tests - Part 1: General Requirements; German version EN 1363-1:2012
- [N2] DIN EN 206:2017-01: Concrete - Specification, performance, production and conformity; German version EN 206:2013+A1:2016
- [N3] DIN EN 10087:1999-01: Free-cutting steels - Technical delivery conditions for semi-finished products, hot-rolled bars and rods; German version EN 10087:1998
- [N4] DIN EN 10088-2:2014-12: Stainless steels - Part 2: Technical delivery conditions for sheet/plate and strip of corrosion resisting steels for general purposes; German version EN 10088-2:2014
- [N5] EN 1992-4:2018: Eurocode 2 - Design of concrete structures - Part 4: Design of fastenings for use in concrete
- [N6] ETAG 001; Guideline for European Technical Approval of metal anchors for use in concrete; April 2013
- [N7] TR 020: Evaluation of Anchorages in Concrete concerning Resistance to Fire; 05/2004
- [N8] EAD 330232-00-0601: Mechanical fasteners for use in concrete; 10/2016
- [N9] DIN EN 1992-1-2:2010-12: Eurocode 2: Design of concrete structures - Part 1-2: General rules - Structural fire design; German version EN 1992-1-2:2004 + AC:2008

2 Reference documents

The analyses are based on the following additional documents:

2.1 Verifications of applicability

- [P1] ETA-10/0260: Sikla Injection System VMZ, Torque controlled bonded anchor with anchor rod VMZ-A and internal threaded rod VMZ-IG for use in concrete – Deutsches Institut für Bautechnik, 04.12.2017



2.2 Assessment and test reports

- [G1] Gutachterliche Stellungnahme Nr. GS 6.1/18-033-1: Bewertung des Tragverhaltens eingeklebter stählerner Verbunddübel VMZ-A, VMZ-IG und VMZ dynamic mit Injektionssystem VMZ unter zentrischem Zug und einseitiger Brandbeanspruchung gemäß Einheits-temperaturzeitkurve – MFPA Leipzig GmbH; 13.09.2018

2.3 Miscellaneous

- [S1] Schreiben des Herstellers an die MFPA Leipzig GmbH zur Bestätigung der Übereinstimmung der Injektionssysteme VMZ; 28.02.2020

IV Assessment of the performance

1 Design concept

The characteristic load bearing capacity of a bonded anchor in case of fire has to be determined as the minimum value of the load bearing capacities for the failure modes steel failure, pull-out failure and concrete cone failure

$$N_{Rk,fi}(t) = \min [N_{Rk,p,fi}(t), N_{Rk,s,fi}(t), N_{Rk,c,fi}(t)] . \quad (1)$$

In case of the failure modes pull-out failure and steel failure, the values specified in Tables 1 to 6 and 7 to 12, respectively, may directly be inserted into equation (1).

With respect to the failure mode concrete cone failure, Tables 13 and 14 show the load bearing capacities $N_{Rk,c,fi}^0(t)$ for a single anchor. The determination of $N_{Rk,c,fi}(t)$ as input quantity for equation (1) is done depending on the specific construction according to [N5], chapter 7.2.1.4 and Appendix D.4.2.2 under consideration of [P1]. Diverging from the instructions of [N5], chapter 7.2.1.4, the cube compressive strength of the surrounding concrete has to be used for f_{ck} , since $k_{cr,N}$ and $k_{ucr,N}$ (see [P1]) have been determined basing on [N6].

2 Pull-out failure

The following tables show the characteristic tensile load bearing capacities $N_{Rk,p,fi}(t)$ of the different bonded anchors for pull-out failure.

		fire duration [min]			
		30	60	90	120
A1-vz	40 M8	0,67	0,0	0,0	0,0
A2-vz	50 M8	1,69	0,07	0,0	0,0
A3-vz	60 M10	3,38	0,83	0,0	0,0
A4-vz	75 M10	5,37	2,36	0,77	0,0
A5-vz	75 M12	6,15	2,74	0,71	0,0
A6-vz	70 M12	4,94	1,67	0,0	0,0
A7-vz	80 M12	7,6	3,11	1,14	0,0
A8-vz	95 M12	10,48	5,71	2,95	1,37
A9-vz	100 M12	14,16	7,78	4,1	2,15
A10-vz	110 M12	16,63	10,0	6,08	3,71
A11-vz	125 M12	19,91	13,37	9,22	6,54
A12-vz	90 M16	9,72	4,61	1,93	0,0
A13-vz	105 M16	15,65	8,62	4,63	2,34
A14-vz	125 M16	26,04	16,2	10,79	6,64
A15-vz	145 M16	31,97	22,33	16,48	12,31
A16-vz	160 M16	39,58	29,39	22,71	17,64
A17-vz	115 M20	18,99	10,79	6,78	3,65
A18-vz	170 M20	50,1	35,77	27,29	21,5
A19-vz	190 M20	56,05	43,14	34,66	28,51
A20-vz	170 M24	62,65	43,17	32,33	24,85
A21-vz	200 M24	74,52	57,36	46,3	38,34
A22-vz	225 M24	81,52	67,29	57,09	49,19

Table 1: Sikla injection system VMZ with anchor rod VMZ-A of galvanized steel: Characteristic tensile load bearing capacity $N_{Rk,p,fi}(t)$ [kN] for pull-out failure

		fire duration [min]			
		30	60	90	120
A1-A4	40 M8	0,99	0,0	0,0	0,0
A2-A4	50 M8	2,17	0,35	0,0	0,0
A3-A4	60 M10	4,46	1,31	0,22	0,0
A4-A4	75 M10	6,83	3,11	1,31	0,31
A5-A4	75 M12	8,18	3,71	1,49	0,39
A6-A4	70 M12	7,03	2,63	0,76	0,0
A7-A4	80 M12	10,37	4,59	1,86	0,56
A8-A4	95 M12	13,78	7,6	4,45	2,36
A9-A4	100 M12	18,21	10,1	5,63	3,22
A10-A4	110 M12	20,87	12,71	8,12	5,06
A11-A4	125 M12	23,97	16,58	11,62	8,36
A12-A4	90 M16	14,55	7,26	3,7	1,6
A13-A4	105 M16	22,08	12,67	7,55	4,36
A14-A4	125 M16	34,41	22,11	14,81	9,81
A15-A4	145 M16	39,84	29,39	21,66	16,31
A16-A4	160 M16	47,42	37,16	28,78	22,56
A17-A4	115 M20	27,56	16,95	10,83	6,97
A18-A4	170 M20	63,27	49,4	38,36	30,19
A19-A4	190 M20	67,01	56,79	46,98	38,85
A20-A4	170 M24	80,94	61,24	46,62	36,24
A21-A4	200 M24	89,11	76,17	63,61	53,13
A22-A4	225 M24	92,11	84,2	74,45	65,28

Table 2: Sikla injection system VMZ with anchor rod VMZ-A of stainless steel A4: Characteristic tensile load bearing capacity $N_{Rk,p,fi}(t)$ [kN] for pull-out failure

		fire duration [min]			
		30	60	90	120
A1-HCR	40 M8	1,02	0,0	0,0	0,0
A2-HCR	50 M8	2,22	0,36	0,0	0,0
A3-HCR	60 M10	4,56	1,35	0,23	0,0
A4-HCR	75 M10	6,99	3,18	1,34	0,32
A5-HCR	75 M12	8,39	3,8	1,64	0,4
A6-HCR	70 M12	7,23	2,71	0,79	0,0
A7-HCR	80 M12	10,64	4,72	1,92	0,58
A8-HCR	95 M12	14,11	7,81	4,58	2,44
A9-HCR	100 M12	18,59	10,33	5,78	3,31
A10-HCR	110 M12	21,26	13,0	8,32	5,19
A11-HCR	125 M12	24,31	16,92	11,87	8,56
A12-HCR	90 M16	15,04	7,53	3,86	1,83
A13-HCR	105 M16	22,7	13,08	7,98	4,55
A14-HCR	125 M16	35,17	22,71	15,26	10,14
A15-HCR	145 M16	40,46	30,09	22,24	16,78
A16-HCR	160 M16	48,0	37,9	29,45	23,12
A17-HCR	115 M20	28,38	17,6	11,29	7,51
A18-HCR	170 M20	64,31	50,69	39,52	31,19
A19-HCR	190 M20	67,73	57,97	48,21	40,0
A20-HCR	170 M24	82,72	62,98	48,12	37,52
A21-HCR	200 M24	90,21	77,79	65,31	54,73
A22-HCR	225 M24	92,72	85,44	75,98	66,87

Table 3: Sikla injection system VMZ with anchor rod VMZ-A of high corrosion resistant steel: Characteristic tensile load bearing capacity $N_{Rk,p,fi}(t)$ [kN] for pull-out failure

		fire duration [min]			
		30	60	90	120
IG1-vz	40 M6	0,67	0,0	0,0	0,0
IG2-vz	50 M6	1,69	0,07	0,0	0,0
IG3-vz	60 M8	3,38	0,83	0,0	0,0
IG4-vz	75 M8	6,15	2,74	0,71	0,0
IG5-vz	70 M10	4,94	1,67	0,0	0,0
IG6-vz	80 M10	7,6	3,11	1,14	0,0
IG7-vz	90 M12	9,72	4,61	1,93	0,0
IG8-vz	105 M12	15,65	8,62	4,63	2,34
IG9-vz	125 M12	26,04	16,2	10,79	6,64
IG10-vz	115 M16	18,99	10,79	6,78	3,65
IG11-vz	170 M16	50,1	35,77	27,29	21,5
IG12-vz	170 M20	62,65	43,17	32,33	24,85

Table 4: Sikla injection system VMZ with anchor rod VMZ-IG of galvanized steel: Characteristic tensile load bearing capacity $N_{Rk,p,fi}(t)$ [kN] for pull-out failure

		fire duration [min]			
		30	60	90	120
IG1-A4	40 M6	0,99	0,0	0,0	0,0
IG2-A4	50 M6	2,17	0,35	0,0	0,0
IG3-A4	60 M8	4,46	1,31	0,22	0,0
IG4-A4	75 M8	8,18	3,71	1,49	0,39
IG5-A4	70 M10	7,03	2,63	0,76	0,0
IG6-A4	80 M10	10,37	4,59	1,86	0,56
IG7-A4	90 M12	14,55	7,26	3,7	1,6
IG8-A4	105 M12	22,08	12,67	7,55	4,36
IG9-A4	125 M12	34,41	22,11	14,81	9,81
IG10-A4	115 M16	27,56	16,95	10,83	6,97
IG11-A4	170 M16	63,27	49,4	38,36	30,19
IG12-A4	170 M20	80,94	61,24	46,62	36,24

Table 5: Sikla injection system VMZ with anchor rod VMZ-IG of stainless steel A4: Characteristic tensile load bearing capacity $N_{Rk,p,fi}(t)$ [kN] for pull-out failure

		fire duration [min]			
		30	60	90	120
IG1-HCR	40 M6	1,02	0,0	0,0	0,0
IG2-HCR	50 M6	2,22	0,36	0,0	0,0
IG3-HCR	60 M8	4,56	1,35	0,23	0,0
IG4-HCR	75 M8	8,39	3,8	1,64	0,4
IG5-HCR	70 M10	7,23	2,71	0,79	0,0
IG6-HCR	80 M10	10,64	4,72	1,92	0,58
IG7-HCR	90 M12	15,04	7,53	3,86	1,83
IG8-HCR	105 M12	22,7	13,08	7,98	4,55
IG9-HCR	125 M12	35,17	22,71	15,26	10,14
IG10-HCR	115 M16	28,38	17,6	11,29	7,51
IG11-HCR	170 M16	64,31	50,69	39,52	31,19
IG12-HCR	170 M20	82,72	62,98	48,12	37,52

Table 6: Sikla injection system VMZ with anchor rod VMZ-IG of high corrosion resistant steel: Characteristic tensile load bearing capacity $N_{Rk,p,fi}(t)$ [kN] for pull-out failure

3 Steel failure

The following tables show the characteristic tensile load bearing capacities $N_{Rk,s,fi}(t)$ of the different bonded anchors for steel failure.

		fire duration [min]			
		30	60	90	120
A1-vz	40 M8	*	*	*	*
A2-vz	50 M8	*	*	*	*
A3-vz	60 M10	*	*	*	*
A4-vz	75 M10	3,38 ^a	1,45	0,39	*
A5-vz	75 M12	5,80	3,80	1,81	*
A6-vz	70 M12	5,80	3,80	1,81	*
A7-vz	80 M12	5,80	3,80	1,81	*
A8-vz	95 M12	5,80	3,80	1,81	0,81
A9-vz	100 M12	5,80	3,80	1,81	0,81
A10-vz	110 M12	5,80	3,80	1,81	0,81
A11-vz	125 M12	5,80	3,80	1,81	0,81
A12-vz	90 M16	7,62	5,81	4,01	3,11
A13-vz	105 M16	7,62	5,81	4,01	3,11
A14-vz	125 M16	7,62	5,81	4,01	3,11
A15-vz	145 M16	7,62	5,81	4,01	3,11
A16-vz	160 M16	7,62	5,81	4,01	3,11
A17-vz	115 M20	9,11	6,83	4,54	3,39
A18-vz	170 M20	13,02	9,75	6,48	4,84
A19-vz	190 M20	13,02	9,75	6,48	4,84
A20-vz	170 M24	18,76	14,05	9,34	6,97
A21-vz	200 M24	18,76	14,05	9,34	6,97
A22-vz	225 M24	18,76	14,05	9,34	6,97

Table 7: Sikla injection system VMZ with anchor rod VMZ-A of galvanized steel: Characteristic tensile load bearing capacity $N_{Rk,s,fi}(t)$ [kN] for steel failure (* steel failure not decisive, ^a value for pull-out failure transferred from Table 1)

		fire duration [min]			
		30	60	90	120
A1-A4	40 M8	*	*	*	*
A2-A4	50 M8	*	*	*	*
A3-A4	60 M10	*	*	*	*
A4-A4	75 M10	5,84	*	*	*
A5-A4	75 M12	10,66	7,01	3,37	*
A6-A4	70 M12	10,66	7,01	3,37	*
A7-A4	80 M12	10,66	7,01	3,37	*
A8-A4	95 M12	10,66	7,01	3,37	1,55
A9-A4	100 M12	10,66	7,01	3,37	1,55
A10-A4	110 M12	10,66	7,01	3,37	1,55
A11-A4	125 M12	10,66	7,01	3,37	1,55
A12-A4	90 M16	16,67	11,79	6,92	4,48
A13-A4	105 M16	16,67	11,79	6,92	4,48
A14-A4	125 M16	16,67	11,79	6,92	4,48
A15-A4	145 M16	16,67	11,79	6,92	4,48
A16-A4	160 M16	16,67	11,79	6,92	4,48
A17-A4	115 M20	23,75	16,7	9,64	6,11
A18-A4	170 M20	23,75	16,7	9,64	6,11
A19-A4	190 M20	23,75	16,7	9,64	6,11
A20-A4	170 M24	34,23	24,06	13,89	8,79
A21-A4	200 M24	34,23	24,06	13,89	8,79
A22-A4	225 M24	34,23	24,06	13,89	8,79

Table 8: Sikla injection system VMZ with anchor rod VMZ-A of stainless steel A4: Characteristic tensile load bearing capacity $N_{Rk,s,fi}(t)$ [kN] for steel failure (* steel failure not decisive)

		fire duration [min]			
		30	60	90	120
A1-HCR	40 M8	*	*	*	*
A2-HCR	50 M8	*	*	*	*
A3-HCR	60 M10	*	*	*	*
A4-HCR	75 M10	5,84	*	*	*
A5-HCR	75 M12	10,66	7,01	3,37	*
A6-HCR	70 M12	10,66	7,01	3,37	*
A7-HCR	80 M12	10,66	7,01	3,37	*
A8-HCR	95 M12	10,66	7,01	3,37	1,55
A9-HCR	100 M12	10,66	7,01	3,37	1,55
A10-HCR	110 M12	10,66	7,01	3,37	1,55
A11-HCR	125 M12	10,66	7,01	3,37	1,55
A12-HCR	90 M16	16,67	11,79	6,92	4,48
A13-HCR	105 M16	16,67	11,79	6,92	4,48
A14-HCR	125 M16	16,67	11,79	6,92	4,48
A15-HCR	145 M16	16,67	11,79	6,92	4,48
A16-HCR	160 M16	16,67	11,79	6,92	4,48
A17-HCR	115 M20	23,75	16,7	9,64	6,11
A18-HCR	170 M20	23,75	16,7	9,64	6,11
A19-HCR	190 M20	23,75	16,7	9,64	6,11
A20-HCR	170 M24	34,23	24,06	13,89	8,79
A21-HCR	200 M24	34,23	24,06	13,89	8,79
A22-HCR	225 M24	34,23	24,06	13,89	8,79

Table 9: Sikla injection system VMZ with anchor rod VMZ-A of high corrosion resistant steel: Characteristic tensile load bearing capacity $N_{Rk,s,fi}(t)$ [kN] for steel failure (* steel failure not decisive)

		fire duration [min]			
		30	60	90	120
IG1-vz	40 M6	*	*	*	*
IG2-vz	50 M6	*	*	*	*
IG3-vz	60 M8	*	*	*	*
IG4-vz	75 M8	3,38 ^a	0,93	0,54	*
IG5-vz	70 M10	2,12	1,58	1,04	*
IG6-vz	80 M10	2,12	1,58	1,04	*
IG7-vz	90 M12	2,93	2,14	1,35	0,95
IG8-vz	105 M12	2,93	2,14	1,35	0,95
IG9-vz	125 M12	2,93	2,14	1,35	0,95
IG10-vz	115 M16	3,82	2,79	1,76	1,24
IG11-vz	170 M16	5,46	3,99	2,51	1,77
IG12-vz	170 M20	8,52	6,22	3,92	2,76

Table 10: Sikla injection system VMZ with anchor rod VMZ-IG of galvanized steel: Characteristic tensile load bearing capacity $N_{Rk,s,fi}(t)$ [kN] for steel failure (* steel failure not decisive, ^a value for pull-out failure transferred from Table 4)

		fire duration [<i>min</i>]			
		30	60	90	120
IG1-A4	40 M6	*	*	*	*
IG2-A4	50 M6	*	*	*	*
IG3-A4	60 M8	*	*	*	*
IG4-A4	75 M8	4,46 ^a	2,02	1,06	*
IG5-A4	70 M10	4,78	3,32	1,85	1,12
IG6-A4	80 M10	4,78	3,32	1,85	1,12
IG7-A4	90 M12	6,82	4,68	2,55	1,48
IG8-A4	105 M12	6,82	4,68	2,55	1,48
IG9-A4	125 M12	6,82	4,68	2,55	1,48
IG10-A4	115 M16	12,7	8,72	4,74	2,75
IG11-A4	170 M16	12,7	8,72	4,74	2,75
IG12-A4	170 M20	19,82	13,61	7,4	4,29

Table 11: Sikla injection system VMZ with anchor rod VMZ-IG of stainless steel A4: Characteristic tensile load bearing capacity $N_{Rk,s,fi}(t)$ [kN] for steel failure (* steel failure not decisive, ^a value for pull-out failure transferred from Table 5)

		fire duration [min]			
		30	60	90	120
IG1-HCR	40 M6	*	*	*	*
IG2-HCR	50 M6	*	*	*	*
IG3-HCR	60 M8	*	*	*	*
IG4-HCR	75 M8	4,56 ^a	2,02	1,06	*
IG5-HCR	70 M10	4,78	3,32	1,85	1,12
IG6-HCR	80 M10	4,78	3,32	1,85	1,12
IG7-HCR	90 M12	6,82	4,68	2,55	1,48
IG8-HCR	105 M12	6,82	4,68	2,55	1,48
IG9-HCR	125 M12	6,82	4,68	2,55	1,48
IG10-HCR	115 M16	12,7	8,72	4,74	2,75
IG11-HCR	170 M16	12,7	8,72	4,74	2,75
IG12-HCR	170 M20	19,82	13,61	7,4	4,29

Table 12: Sikla injection system VMZ with anchor rod VMZ-IG of high corrosion resistant steel: Characteristic tensile load bearing capacity $N_{Rk,s,fi}(t)$ [kN] for steel failure (* steel failure not decisive, ^a value for pull-out failure transferred from Table 6)

4 Concrete cone failure

The following tables show the characteristic tensile load bearing capacities $N_{Rk,c,fi}^0(t)$ of the different bonded anchors for concrete cone failure of one single anchor.

		fire duration [min]			
		30	60	90	120
A1	40 M8	1,82	1,82	1,82	1,46
A2	50 M8	3,18	3,18	3,18	2,55
A3	60 M10	5,02	5,02	5,02	4,02
A4	75 M10	8,77	8,77	8,77	7,01
A5	75 M12	8,77	8,77	8,77	7,01
A6	70 M12	7,38	7,38	7,38	5,90
A7	80 M12	10,30	10,30	10,30	8,24
A8	95 M12	15,83	15,83	15,83	12,67
A9	100 M12	18,00	18,00	18,00	14,40
A10	110 M12	22,84	22,84	22,84	18,27
A11	125 M12	31,44	31,44	31,44	25,16
A12	90 M16	13,83	13,83	13,83	11,07
A13	105 M16	20,34	20,34	20,34	16,27
A14	125 M16	31,44	31,44	31,44	25,16
A15	145 M16	45,57	45,57	45,57	36,46
A16	160 M16	58,29	58,29	58,29	46,63
A17	115 M20	25,53	25,53	25,53	20,42
A18	170 M20	67,83	67,83	67,83	54,26
A19	190 M20	89,57	89,57	89,57	71,65
A20	170 M24	67,83	67,83	67,83	54,26
A21	200 M24	101,82	101,82	101,82	81,46
A22	225 M24	121,50	121,50	121,50	109,35

Table 13: Sikla injection system VMZ with anchor rod VMZ-A (all materials): Characteristic tensile load bearing capacity $N_{Rk,c,fi}^0(t)$ [kN] of a single anchor for concrete cone failure

		fire duration [<i>min</i>]			
		30	60	90	120
IG1	40 M6	1,82	1,82	1,82	1,46
IG2	50 M6	3,18	3,18	3,18	2,55
IG3	60 M8	5,02	5,02	5,02	4,02
IG4	75 M8	8,77	8,77	8,77	7,01
IG5	70 M10	7,38	7,38	7,38	5,90
IG6	80 M10	10,30	10,30	10,30	8,24
IG7	90 M12	13,83	13,83	13,83	11,07
IG8	105 M12	20,34	20,34	20,34	16,27
IG9	125 M12	31,44	31,44	31,44	25,16
IG10	115 M16	25,53	25,53	25,53	20,42
IG11	170 M16	67,83	67,83	67,83	54,26
IG12	170 M20	67,83	67,83	67,83	54,26

Table 14: Sikla injection system VMZ with anchor rod VMZ-IG (all materials): Characteristic tensile load bearing capacity $N_{Rk,c,fi}^0(t)$ [kN] of a single anchor for concrete cone failure

V Special notes

The assessment at hand is valid for bonded anchors VMZ-A and VMZ-IG with Sikla injection system VMZ (mortar cartridge VMZ or VMZ express) manufactured by Sikla Holding GmbH which are installed according to the manufacturers' instructions in [P1]. The mechanical loading may not exceed the load bearing capacity in ambient climate specified in [P1].

The load bearing capacities specified in the framework of the document at hand are determined for one-sided fire loading according to the standard-time-temperature-curve. According to [N7], the values may also be used for multilateral fire loading when the edge distance of the anchor is $c \geq 300mm$ and $c \geq 2 \cdot h_{ef}$.

The load bearing capacities specified in the framework of the document at hand are determined for central tensile loading in the anchors longitudinal direction. According to [N8], the values may be transferred to tensile loading perpendicular and diagonal to the axis of the anchor on the safe side.

The load bearing capacities specified for the internal threaded rods VMZ-IG made of galvanized steel are valid in conjunction with threaded rods of the strength class ≥ 8.8 and nuts of the strength class ≥ 8 . For internal threaded rods VMZ-IG made of stainless steel A4 and high corrosion resistant steel, screws, threaded rods and nuts of the strength class ≥ 70 have to be utilized.

The assessment at hand is valid for constructions of reinforced or unreinforced normal concrete of the strength class $\geq C20/25$ and $\leq C50/60$ according to [N2], which exhibit at least the same fire resistance class as the utilized anchors. The design of the concrete construction has to be carried out according to [N9].

The load bearing capacities specified in the framework of the document at hand are determined assuming that no explosive concrete spalling occurs and are only valid under this condition. Evidence on the prevention of explosive concrete spalling is given in [N9], chapter 4.5.

Author: **MFPA Leipzig GmbH - Center for Innovation and Calculation**
Hans-Weigel-Str 2b • 04319 Leipzig, Germany • +49 (0) 341-6582-106



Proj.-No.: GS 6.1/20-016-1

Type: Advisory Opinion

ASB-Nr.:

Date: 31.03.2020

This document does not replace a certificate of conformity or suitability according to national and European building codes.

Leipzig, 31.03.2020

A handwritten signature in blue ink, appearing to read 'S. Reichel', is written over a horizontal line.

Dr.-Ing. S. Reichel
Head of Business Division

V Special notes